

# Series C44 & C94 Ball Valve

Three Piece C94 and Flanged C94 Valves for control and shutoff of dry, liquid and gaseous chlorine

Valbol has the quality solution for tough applications involving chlorine, from the manufacture of the basic chemical to processes involving its use including pulp and paper bleaching and production of feedstocks. With many years experience in handling dry chlorine, Valbol offers two Basic Models of valves; the Series C44 and C94 for general service and anti-fugitive emission containment and high cycle applications.

All valves feature leak tight seats, adjustable stem seals, body cavity pressure relief and corrosion resistant materials. An emission monitoring port is standard with the C94 design.

## Features

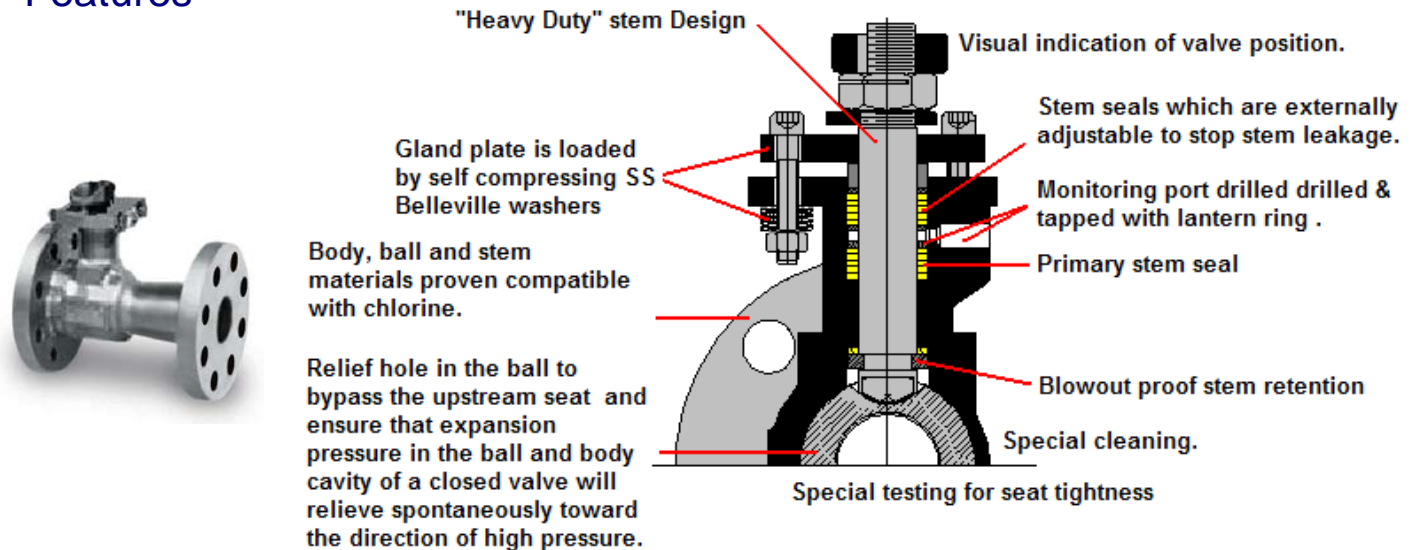

## Chlorine Institute Specifications

All of Valbol Chlorine Ball Valves are constructed in accordance with the guidelines of the Chlorine Institute as outlined in Pamphlet 6, Piping Systems for Dry Chlorine.

## Seats will seal in both directions – providing added safety VPV 94 Control Valve for Throttling Gas or Liquid Chlorine

Ball and Stem Materials:

- Clean 20 ppm Monel ball and stem
- 50 ppm Hastelloy C ball, Monel stem
- 150 ppm Hastelloy C ball and stem

## Material Recommendations for C 44 & C94 valves

The traditional globe style control valve for throttling applications of chlorine liquid or gas has been the most difficult component of the loop to maintain. Corrosion of the valve shaft, sticking actuators, leaky packings are now more than ever very serious concerns. To completely eliminate all these problems, the flanged VPV 94 valve (characterized seat Series 94) with carbon steel body, Hastelloy C® ball and stem, characterized seat and C/fill upstream seat with your choice of Series 38 Pneumatic or Series 73 Electric actuator and positioner is highly recommended for your chlorine throttling applications.

## Relief Hole Upstream (Preferred Direction)

The valve seals against the downstream seat and the cavity pressure will vent upstream as recommended in pamphlet 6.

# Specifications

## C94 3-Piece Valves

**Sizes:** 1/2", 3/4", 1", 1.1/2", 2"

**2 - Ends:** Screwed Ends, Socket Weld, Carbon Steel ASTM A105

**1 - Body Materials:** Carbon Steel

**5 - Stem:** Monel, Hastelloy C or Alloy 20, One-piece construction with increased stem support for high cycling.

**7 - Stem Seals:** Virgin PTFE

**8 - Seat/Seal:** TFE/C/fill one piece seat/seal allows flow in both directions

**3 - Ball:** Monel, Hastelloy C or Alloy 20, with hole in ball and stem slot

**Flow:** This is a bi-directional valve. It is recommended that the valve be installed with ball relief hole upstream to ensure that cavity relief is upstream as suggested in Chlorine Institute Pamphlet 6.

**Leak-off Port:** 1 leak-off port drilled and tapped to 1/8" NPT standard. Optional second port for purging.

**Options:** Oval handles and locking handles available.

**Operation:** Lever handle std., pneumatic or electric actuators are optional.

**Standards:** ANSI B1.20.1 (for SE NPT threads) B16.11, B31.1, B31.3 (including Category M) and MSS SP-72

Chlorine Institute Pamphlet 6, "Piping Systems for Dry Chlorine." ANSI B16.34 dimensional requirements.

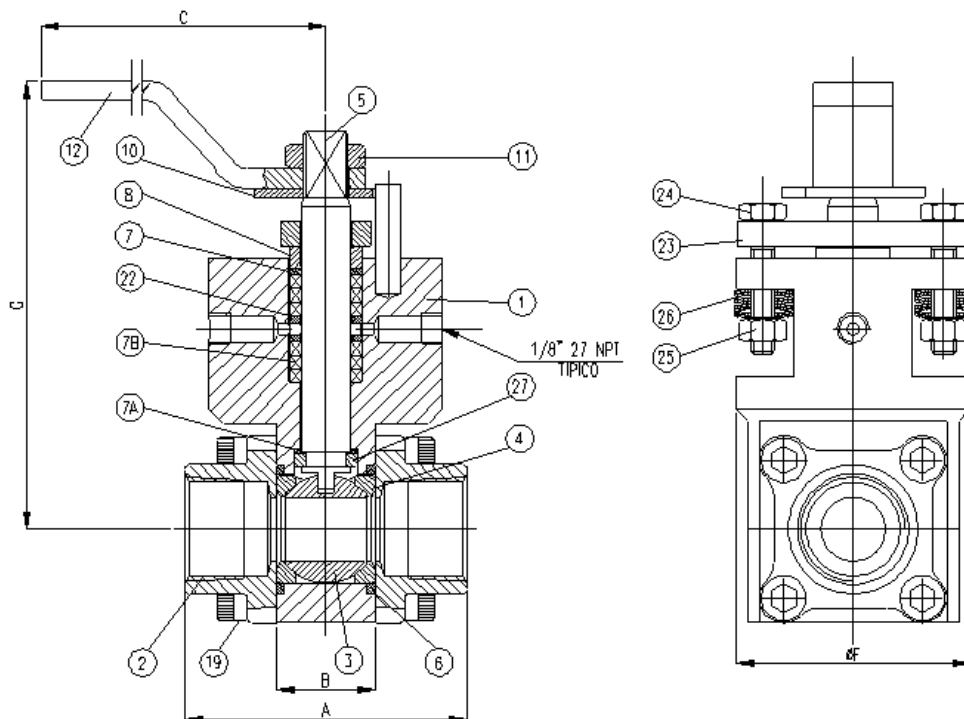

Dimensions for C94 3-Piece Valves (mm.)

#VALV.	A	B	C	F	G
1/4"	94.0	31.7	165.0	75.0	164.0
3/8"	94.0	31.7	165.0	75.0	164.0
1/2"	94.0	31.7	165.0	75.0	164.0
3/4"	94.0	31.7	165.0	75.0	164.0
1"	94.0	31.7	165.0	75.0	164.0
1 1/4"	115.0	48.32	260.0	90.0	174.0
1 1/2"	115.0	48.32	260.0	90.0	174.0
2"	128.0	58.3	260.0	100.0	178.0

# C94 Flanged Valves

**Sizes:** 2", 3", 4", 6".

**Flanges:** C94 150 (ANSI Class 150 raised face) C94 300 (ANSI Class 300 raised face)

**1 - Body:** Carbon Steel ASTM A216-WCB

**5 - Stem:** Monel or Hastelloy C, one-piece construction with increased stem support for high cycle.

**7 - Stem Seals:** Virgin PTFE

**4 - Seats:** Reinforced PTFE

**6 - Body Seal:** PTFE

**3 - Ball:** Monel or Hastelloy C with hole in ball and stem slot

**2 - End Plug:** Carbon Steel, Blackodized Threaded Style.

**Flow:** This is a bi-directional valve. It is recommended that the valve be installed with ball relief hole upstream to ensure that cavity relief is upstream as suggested in Chlorine Institute Pamphlet 6.

**Leak-off Port:** 1 leak-off port drilled and tapped to 1/8" NPT standard. Optional second port for purging.

**Operation:** Lever handle std. pneumatic or electric actuators are optional.

**Standards:** ANSI B16.5 (flange dimensions), B16.10 (face-to face dimensions), B31.1, B31.3 (including Category M materials) and MSS SP-72. Chlorine Institutes guidelines including those specified in Pamphlet 6 "Piping Systems for Dry Chlorine". ANSI B16.34 dimensional requirements.

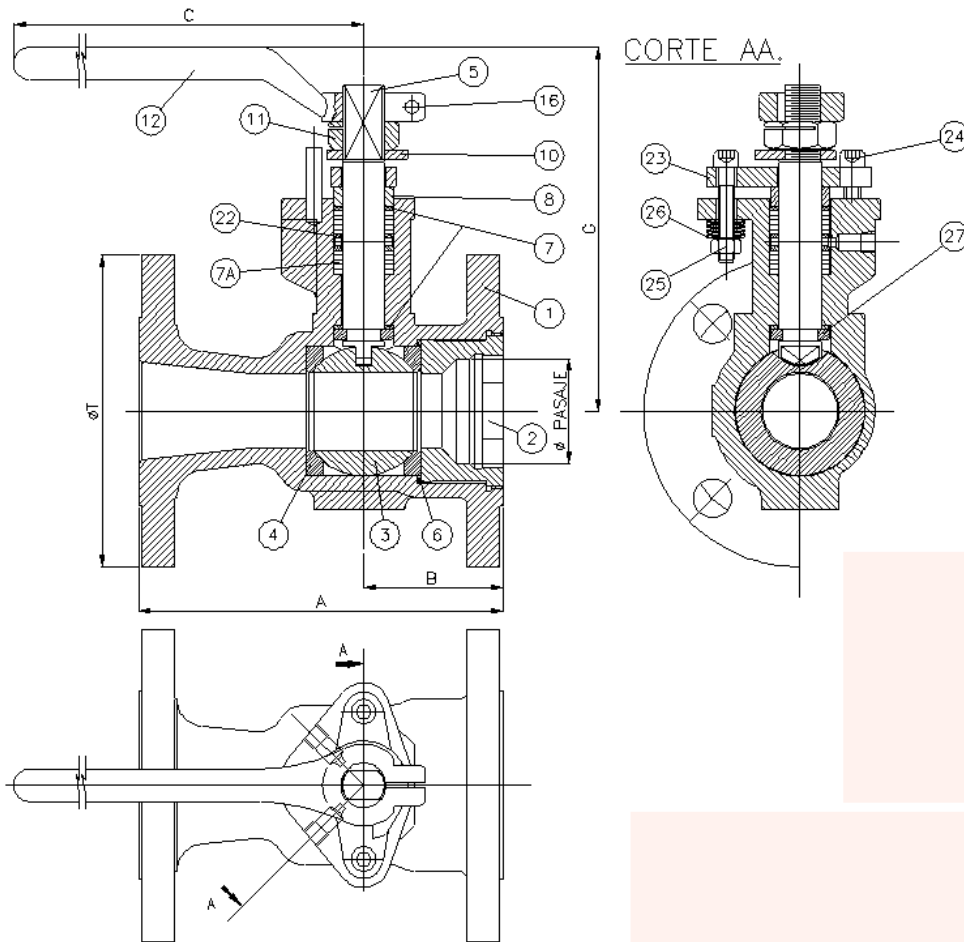

Dimensions for C94 Flanged Valve (mm.)

Ø VALV.	PASAJE	A	B	C	G	T
2"	36.5	177.8	68.0	260.0	178.0	152.4
3"	63.5	203.2	92.3	465.0	166.0	190.5
4"	82.5	228.6	101.8	465.0	180.0	228.6
6"	111.0	266.7	108.1	541.0	251.0	266.7

## Pressure Temperature Rating

Carbon Steel is limited to 20°F for service at lower temperatures consult VALBOL

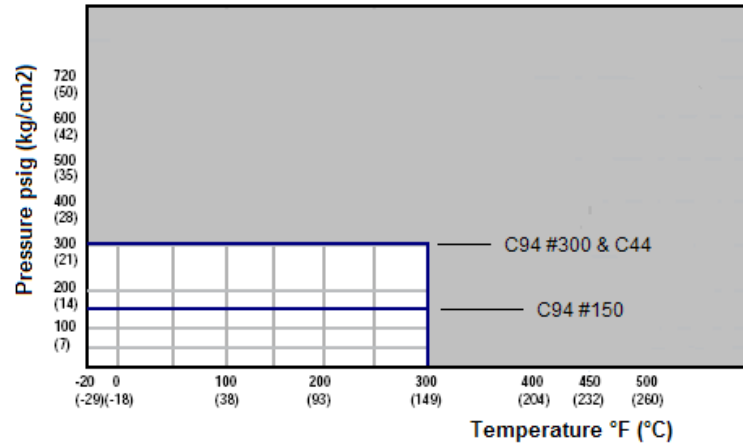

Valves must NOT be used in this region

## Instructions to Order

1. Model	2. Size	3. Options	4. Body	5. Ball & Stem	6. Seat	7. Body Seals	8. Ends	9. Operator
<b>C94</b>	05-DN15 (1/2") 07-DN20 (3/4") 10-DN25 (1") 12-DN32 (1.1/4") 15-DN40 (1.1/2") 20-DN50 (2")	0-Standard 1-More than one A-Antistatic C-Chlorine service G-Locking handle H-High pressure I-Padlocking handle R-Spring return handle	4 - C.Steel	7 - Monel A - Alloy 20 C - Hastelloy	T - PTFE	T - PTFE V - Viton	1 - Flanged 150RF 3 - Flanged 300RF B - BSPT N - NPT P - BSP S - SW pipe T - SW tube V - BW tube W - BW pipe X - Ext. BW	A - Actuator M - Wrench N - Bare stem

1. Model	2. Size	3. Options	4. Body	5. Ball & Stem	6. Seat	7. Body Seals	8. Ends	9. Operator
<b>C94</b>	20-DN50 (2") 30-DN80 (3") 40-DN100 (4") 60-DN150 (6")	0 - Standard 1 - More than one A - Antistatic G - Locking handle	4 - C.Steel	7 - Monel C - Hastelloy	T - PTFE	T - PTFE V - Viton	1 - Flanged 150RF 3 - Flanged 300RF	A - Actuator C - Gear M - Wrench N - Bare stem

### Ordering Example

1	2	3	4	5	6	7	8	9
<b>C94</b>	<b>40</b>	<b>0</b>	<b>4</b>	<b>7</b>	<b>T</b>	<b>T</b>	<b>1</b>	<b>M</b>



**Válvulas Worcester de Argentina S.A.**  
 Osvaldo Cruz 3333 - (C1293DL) Buenos Aires - Argentina  
 Tel: 54(11)4303-0037 Fax: 54(11)4301-8694  
 e.mail:mail@valbol.com Internet: www.valbol.com

Bul. VB94/3 03-2